



## Prediction of Sound Transmission through Elastomeric Bulb Seals

Serkan ATAMER<sup>1</sup>; Mehmet ÇALIŞKAN<sup>2</sup>; Gökhan O. ÖZGEN<sup>3</sup>

<sup>1</sup> Middle East Technical University, Department of Mechanical Engineering, Ankara, 06800, Turkey;  
Mezzo Stüdyo, Ankara, 06800, Turkey

<sup>2</sup> Middle East Technical University, Department of Mechanical Engineering, Ankara, 06800, Turkey

<sup>3</sup> Middle East Technical University, Department of Mechanical Engineering, Ankara, 06800, Turkey

### ABSTRACT

Doors are the weakest parts of the buildings in terms of sound transmission. Examination of sound transmission loss characteristics of doors reveals two separate transmission paths to be considered. First one is transmission through door leaf and the second one is leak transmission through elastomeric bulb seals. Seals are the important parts of the sound transmission loss characteristic of door structure. Hence, their insulation capability should be analyzed and optimized to improve sound transmission loss of an acoustical door.

The aim of this research is to predict sound transmission loss of elastomeric bulb seals. This assessment includes two main steps. A static analysis is required to determine the seal shape under compression. Seals are made of elastomers which display nonlinear mechanical behavior. This requires hyperelastic material modeling and nonlinear finite element analysis (FEA). An acoustic analysis calculating the sound transmission is then carried on deformed geometry acquired from the first phase of the research.

A sample seal geometry, which is already being used in industry, is considered as the case study. Influences of different hyper elastic material models on sound insulation are also studied.

Keywords: Sound Transmission Loss, Elastomeric Bulb Seals, Hyperelasticity

### 1. INTRODUCTION

Elastomeric rubber seals are frequently used in different industries to prevent water, heat and noise intrusion from one volume to the other. Analysis and improvement of their thermal and noise insulation performance becomes more and more pronounced and important every day.

Bulb seals constitute the weakest link in the transmission chain in terms of heat and noise insulation performance. They are important joints in the whole structure. In most of the applications, like the sound transmission loss capacity of a structure having elastomeric bulbs seals, inconvenient sealing applications can reduce effectiveness of the system drastically. Hence, it is important to analyze and improve some of the physical behavior of the rubber seals for accurate prediction of sound transmission loss characteristic of the whole assembly.

The analysis requires deformed sealant geometry under specified compression ratios. Then, sound transmission loss values of the deformed sealant geometries to be determined based on such loading conditions. Analyses conducted in this work constitute two main parts. In the first part, seals are modeled as hyperelastic materials to obtain the deformed geometry under compression. Second part includes the sound transmission loss analysis of these deformed seal geometries.

---

<sup>1</sup> satamer@gmail.com

<sup>2</sup> caliskan@metu.edu.tr

<sup>3</sup> gozgen@metu.edu.tr

## 2. STATIC ANALYSIS

### 2.1 Seal Geometry and FEA Model

The section of seal geometry that is used in this research is given in Figure 1. From this geometry, a 3D model is obtained by defining new bodies representing the air inside and outside the geometry. The 3D model is illustrated in Figure 2.

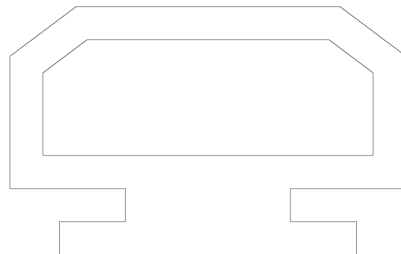

Figure 1 - Section of the seal geometry that is used

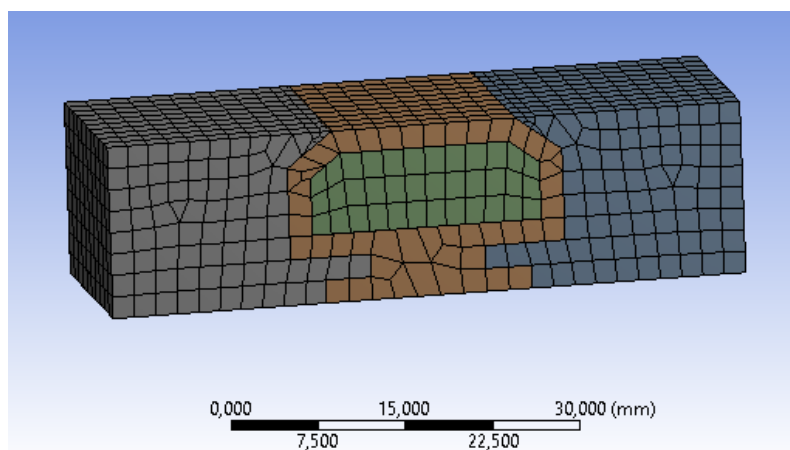

Figure 2 - FEA model of the seal and air

FEA model includes 4 main parts. One part is assigned for the sealant material, and three parts for the air inside and outside of the sealant. Model consists of 2456 elements and 13732 nodes. Information related to mesh statistics is given in Table 1.

Table 1 – Mesh statistics

Mesh Metric	Min	Max	Average	Standard Dev.	Definition
Element Quality	0.301194	0.999999	0.936033	0.126064	0: Elements having nearly zero volume
					1: perfect cube element
					1: Square or equilateral triangle elements
Aspect Ratio	1	7.6444	1.38923	0.833945	20: Square or triangle elements which are too deformed
Jacobian Ratio	1	6.9659	1.29141	0.67899	1: Elements which have perfect triangle or rectangle having no midside nodes
					1000: Elements having midside nodes so that any increase in Jacobian ratio would break the element

## 2.2 Material Characterization

There are two materials to be defined for the analysis: hyperelastic seal and air. For the hyperelastic material characterization, two different material constants set from three different hyperelastic material models are taken from the literature. Table 2 shows the cases for hyperelastic material models and material constant sets.

Table 2 - Hyperelastic material characterization constants

Case	Hyperelastic Material Model	Material Constant Set
1	3rd order Ogden(1)	$\mu_1 = 0.63MPa$ $\mu_2 = 0.0012MPa$ $\mu_3 = -0.01MPa$ $\alpha_1 = 1.3MPa$ $\alpha_2 = 5.0MPa$ $\alpha_3 = -2.0MPa$
2	Arruda-Boyce (2)	$\mu = 0.033379MPa$ $\lambda_L = 0.9736532$

The other material definition is the air. Air is an important part for the acoustic analysis. However, for the consistency of whole analysis, air is also modeled for the static analysis part since the deformed geometries are imported directly from static analysis to the harmonic analysis.

In order to exclude the effect of air deformation on sealant and ensure the model integrity, air is modeled as a dummy material having nearly zero Young's modulus and zero Poisson's ratio. Zero modulus value would yield nearly zero response force and zero Poisson's ratio would provide no lateral deformation on air part when the sealant system is deformed from the top surface.

## 2.3 FEA Results

In two different cases, different hyperelastic material models are defined in elastomers. Both of them are subjected to same boundary conditions and loading conditions. In order to differentiate the resulting deformed geometry, total deformation results are obtained for both cases. Interior air cavity pressure is ignored in the static analysis.

Analyses are performed in ANSYS software. ANSYS is capable of modeling nonlinear hyperelastic material behavior with large deformations. Newton-Raphson method is used for solving nonlinear problems. For both cases, information about the convergence criteria is given in Appendix. The structure experiences a 2 mm deformation downwards.

Figures 3 and 4 show the total deformation in mm for Case 1. Figure 3 displays the deformation of seal geometry, while Figure 4 illustrates the deformation of surrounding air structure. Results obtained for these cases are given in Figures 5 and 6, respectively.

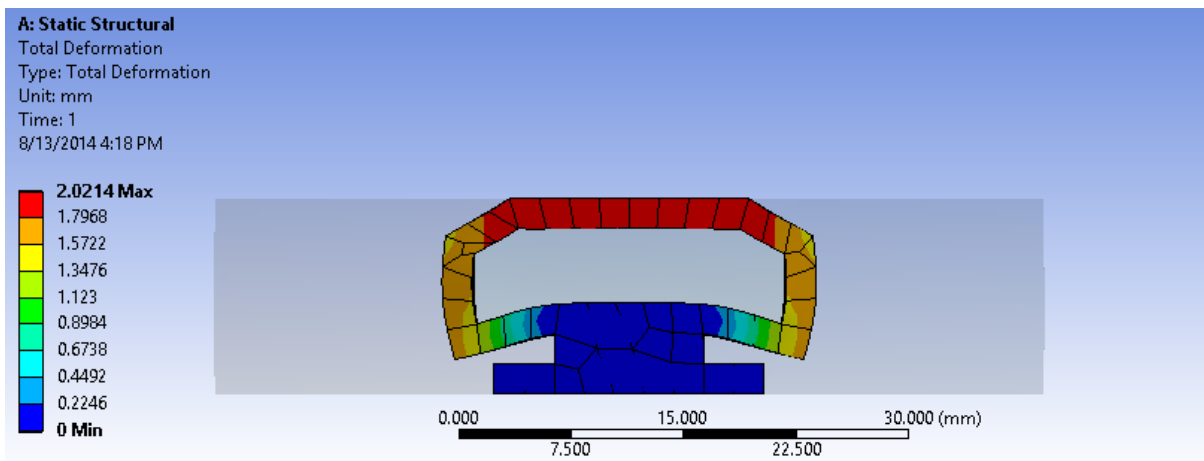

Figure 3 - Total deformation of seal geometry, Case 1

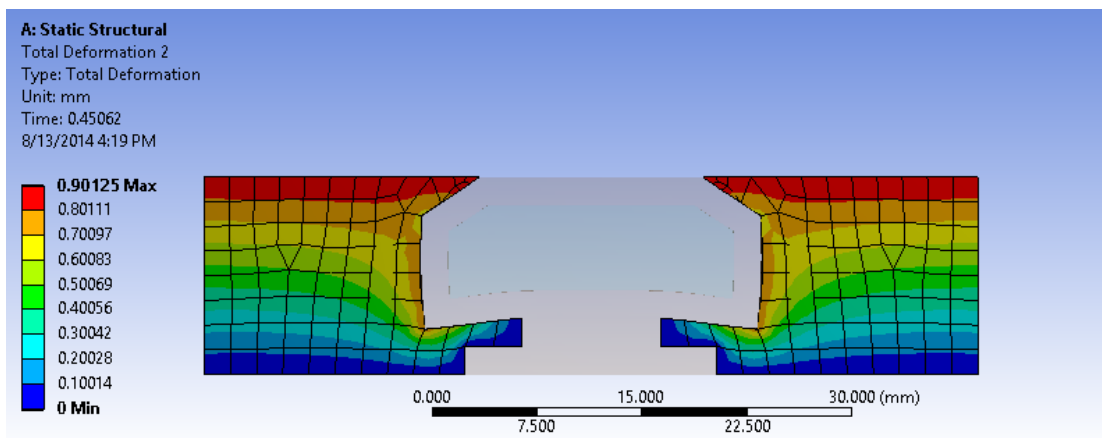

Figure 4 - Total deformation of air, Case 1

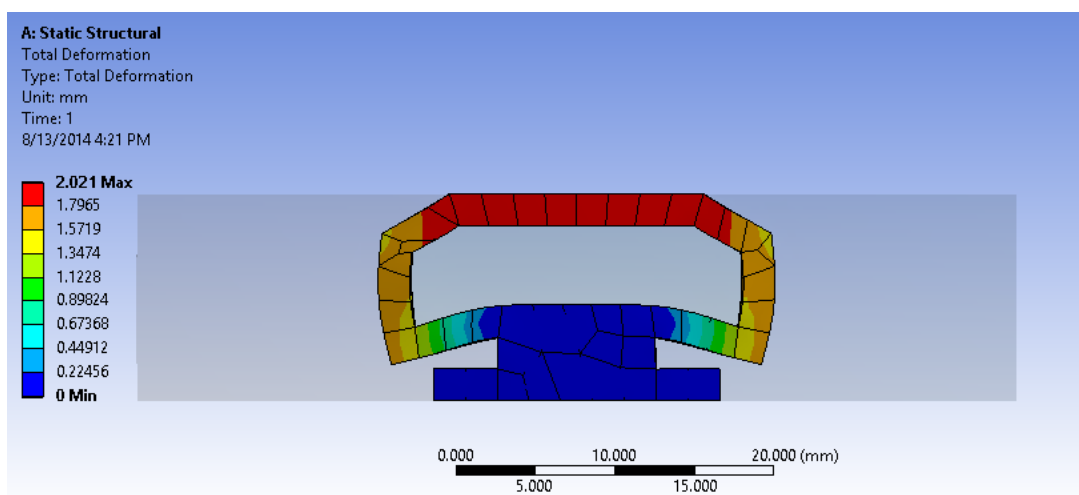

Figure 5 - Total deformation of seal geometry, Case 2

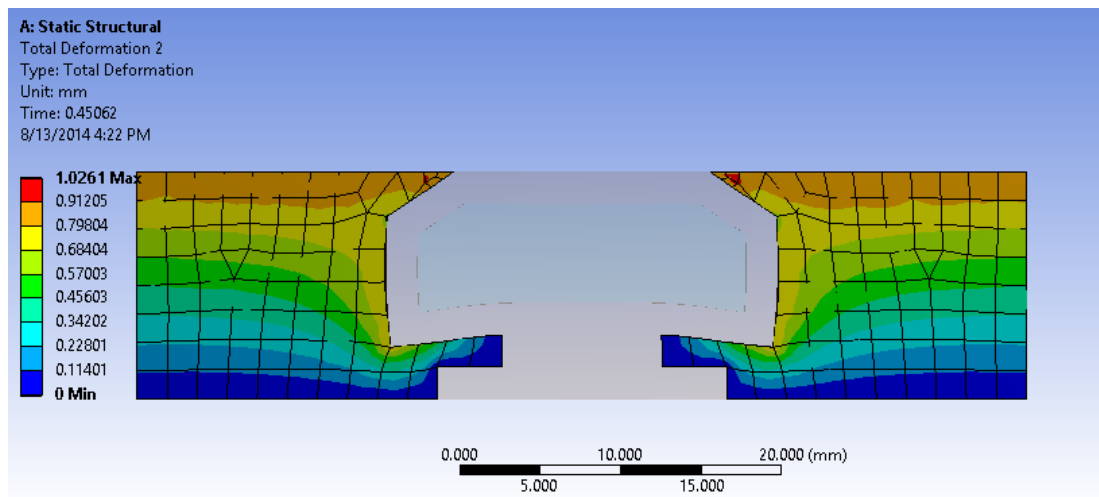

Figure 6 - Total deformation of air, Case 2

### 3. ACOUSTIC ANALYSIS

#### 3.1 Deformed seal geometry and FEA model

Deformed FE model is obtained by tracking the coordinates of the nodes in static structural analysis. From these new coordinates, the deformed model is generated. For the acoustic analysis, body under 2mm deformation is used. Figure 7 shows the deformed geometry used as an initial geometry in harmonic analysis.

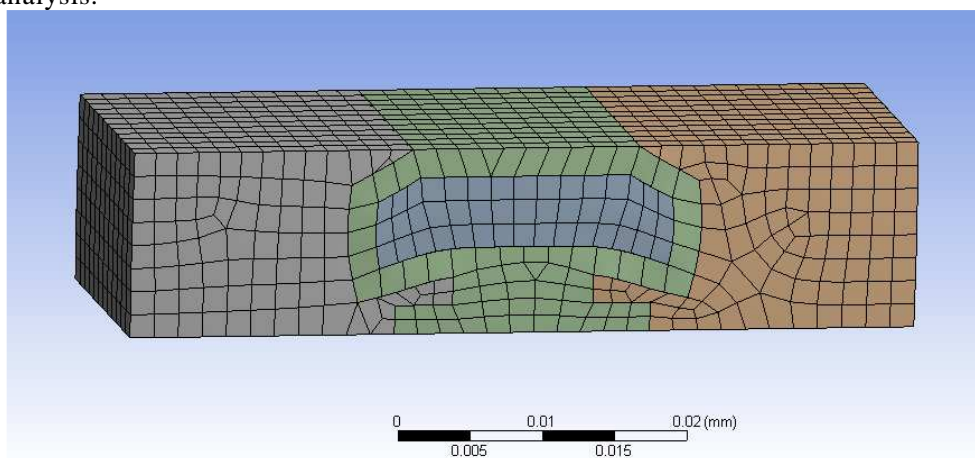

Figure 7 - Deformed geometry and mesh used in acoustic FEA

#### 3.2 Material Characterization

Air and elastomer are modeled in this part. Air is defined as an acoustic body in which Helmholtz equation is considered. The fluid is assumed to be compressible and without any mean flow. Viscous effects and temperature dependent parameters are also neglected. Mass density of the air is taken as  $1.2041 \text{ kg/m}^3$  and speed of sound is defined as  $343.24 \text{ m/s}$

Elastomers have frequency dependent modulus and damping characteristics. However, frequency dependency is overlooked in the assignment of these parameters in this study. The rubber bulk modulus is considered infinite as the seal in this application is not highly confined. The temperature and time dependent material properties of elastomer are also not considered in this work.

### 3.3 FEA Results

For the acoustic FEA, 4 parts are modeled. Three air parts are defined as acoustic bodies with already mentioned characteristics. Moreover, all of the acoustic bodies are modeled to possess acoustic-structure coupling. Hence, acoustic FSI interfaces are also defined in the model. Lastly, acoustic radiation boundary conditions are applied at the inlet and outlet section of the model to characterize non-reflective boundary conditions.

Acoustic boundary condition, by default, is the rigid wall Neumann boundary condition. This is a symmetry condition that can reduce the model size. As an acoustic excitation, harmonic normal surface velocity with amplitude of 0.1 mm/s is applied at the inlet section of the model.

In order to verify FEA model, the case of two independent membranes separated by an air gap was treated. The same boundary conditions and excitations are applied to the simplified model, and results are compared with the data obtained from transfer matrix method that Park et al. realized.

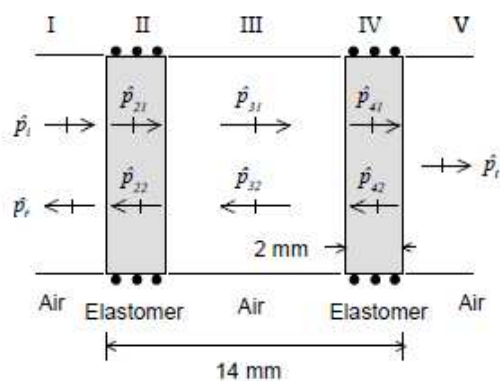

Figure 8 - Dual membrane model (Taken from: J. Park et al. Sound Transmission through Elastomeric Bulb Seals) (3)

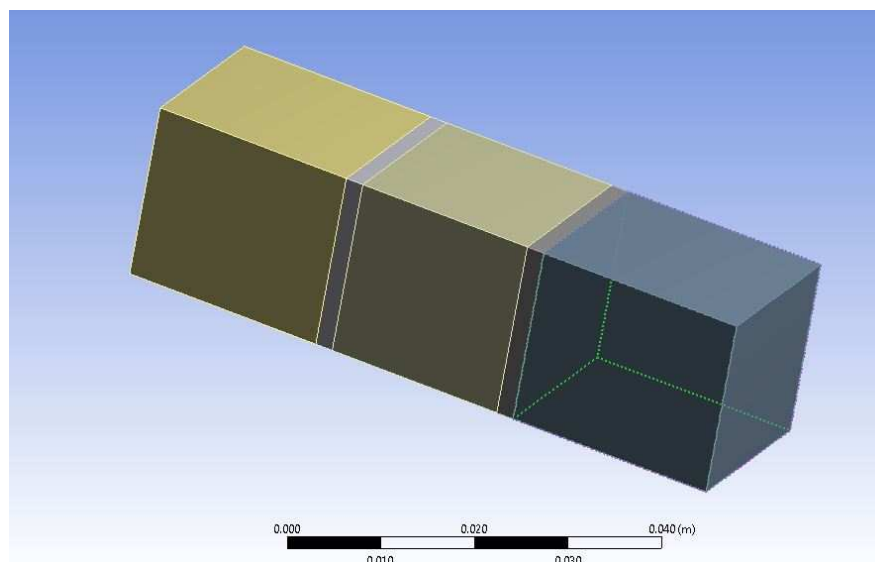

Figure 9 - FE model of dual membrane approximation

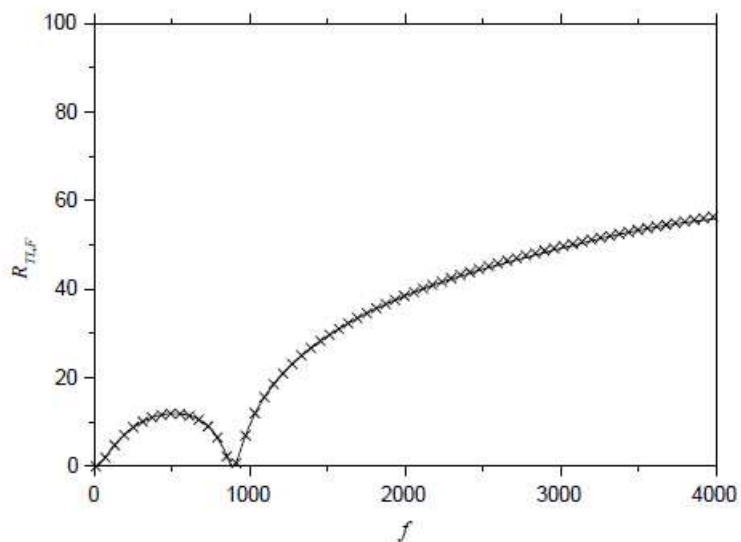

Figure 10 - TL obtained from dual membrane model, by transfer matrix method (Taken from: J. Park et al. Sound Transmission through Elastomeric Bulb Seals)(3)

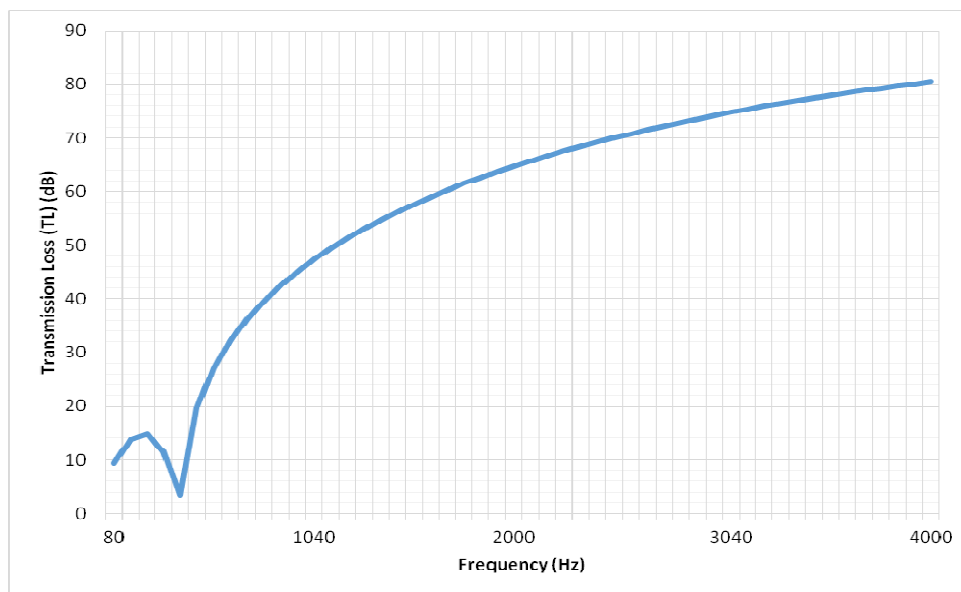

Figure 11- TL obtained from FEA of dual membrane model

Then, results obtained from full model are given in Figure 12.

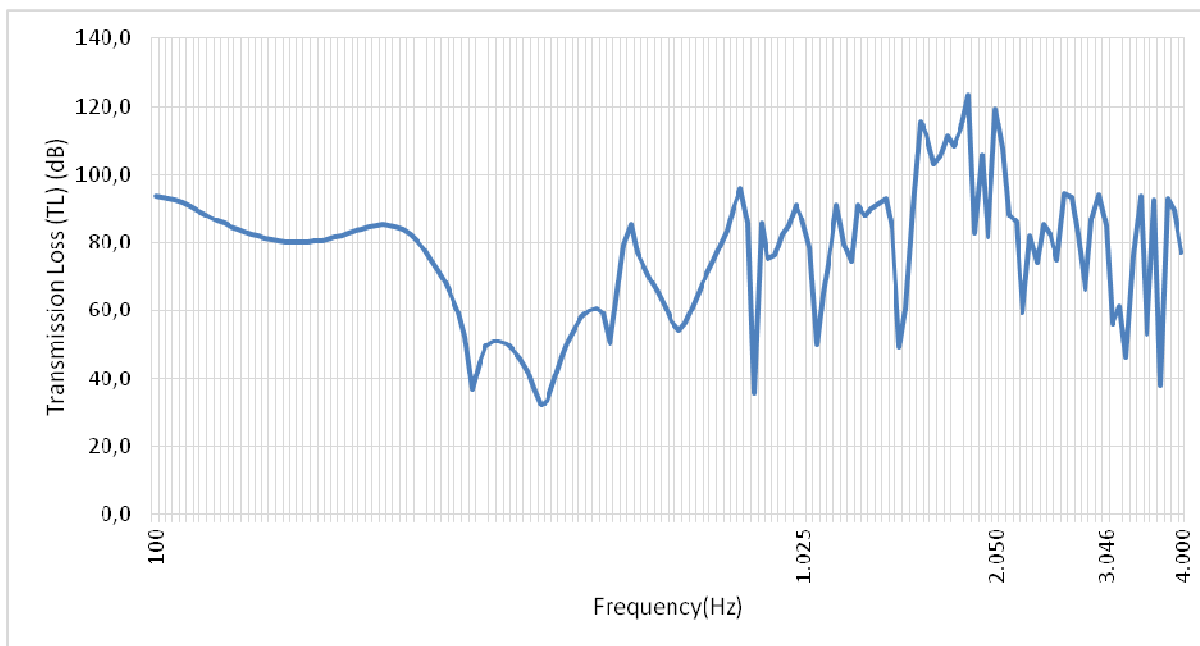

Figure 12 - TL obtained from full model

#### 4. DISCUSSIONS AND CONCLUSIONS

Hyperelasticity is always a burden in FEA. It has nonlinear behavior since the body undergoes a large deformation and the material itself has nonlinear stress-strain relation. Using nonlinear solvers and defining proper time steps can solve nonlinear problems.

For the characterization of hyperelastic materials, since the stress-strain relationship is not linear, constant value of modulus is not enough. Materials should be tested to obtain their tension, compression and shear behavior to get nonlinear stress-strain curves. From these curves, hyperelastic material models can fit a curve to acquire material constants. In this work, two different sets of material constants are taken from literature. One of them employs 3rd order Ogden model, while the other applies an Arruda-Boyce model.

In this study, total deformation is important rather than loading conditions on elastomeric seal. From this perspective, different material constants give almost identical results in terms of total deformation. Taken into account of the fact that, elastomers can differ in composition and different compositions can lead to different mechanical behavior, a future work can be done by testing the material sample having same composition with the evaluated seal geometry. This will yield more reasonable results in obtaining deformed geometry.

Deformed geometry is carried from the static structural analysis to harmonic analysis in ANSYS environment, to relieve the necessity of any other mesh generator. New coordinates of the nodes in static structural analysis after deformation are tracked to generate new surfaces in harmonic analysis.

Acoustic analysis is done using Acoustics\_ACT extension in ANSYS. This extension eliminates the need for APDL in acoustic analyses.

In order to verify the FE model, a simplified analysis is performed on the dual membrane model that mimics the sound transmission characteristics of the sealant. The trend obtained from simplified FEA is coherent with the result obtained from transfer matrix method performed by Park et al (3). Frequencies where the TL takes its lowest value differ though as separation distances between the membranes are not the same leading to different cavity resonance frequencies.

The same boundary conditions and excitations are applied to the full model since the trend between analytic methods and numerical analysis are quite similar. Sound transmission loss values are obtained by defining acoustical ports at the inlet and exit of the model, and correlating the acoustic power between these ports. Obtained results and trends are coherent with the similar studies (4).

Different sealant geometries can be analyzed and optimum seal geometry can be obtained for future work. Hyperelastic material modeling should be done by material testing, since the composition plays



crucial role in mechanical properties of elastomer. Effects of different compression ratios on sound transmission loss should be analyzed.

**REFERENCES**

1. MSC Software, Nonlinear FEA of Elastomers, Technical Paper, [http://www.mscsoftware.com/assets/103\\_elast\\_paper.pdf](http://www.mscsoftware.com/assets/103_elast_paper.pdf)
2. Dikmen E.; Başdoğan I. Material Characteristics of a Vehicle Door Seal and Its Effect on Vehicle Vibrations. In: Vehicle System Dynamics Vol. 46, No. 11, November 2008, 975-990
2. COMSOL Software Technical Paper, Hyperelastic Seal [http://www.comsol.asia/model/download/186047/models.nsm.hyperelastic\\_seal.pdf](http://www.comsol.asia/model/download/186047/models.nsm.hyperelastic_seal.pdf)
3. Park.J, et al. Sound Transmission through Elastomeric Bulb Seals, Journal of Sound and Vibration,2003, 259(2), 299-322
4. Gur Y., Norman K.. Sound Transmission Analysis of Vehicle Door Sealing System, SAE Technical Paper Series, 1999-01-1804

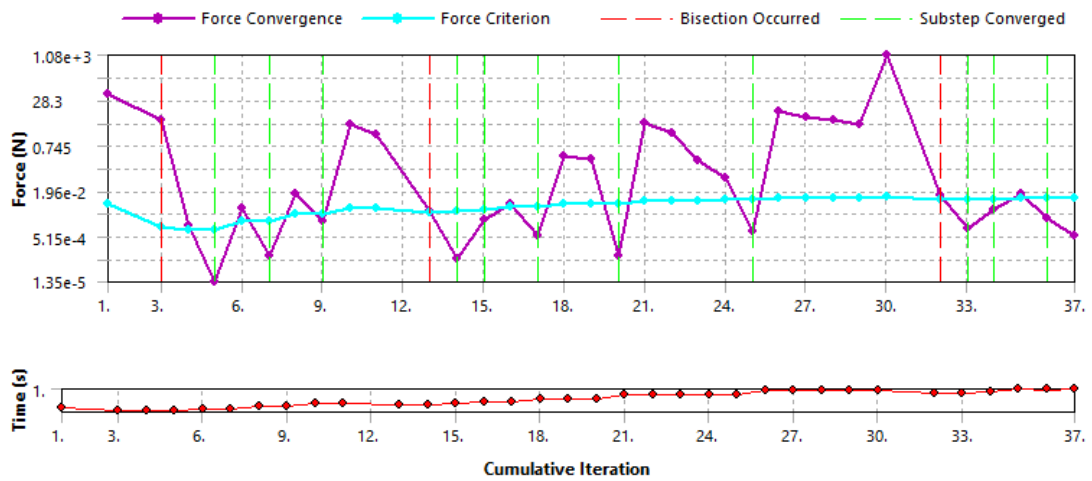

Figure 13 - Force convergence information, Case 1

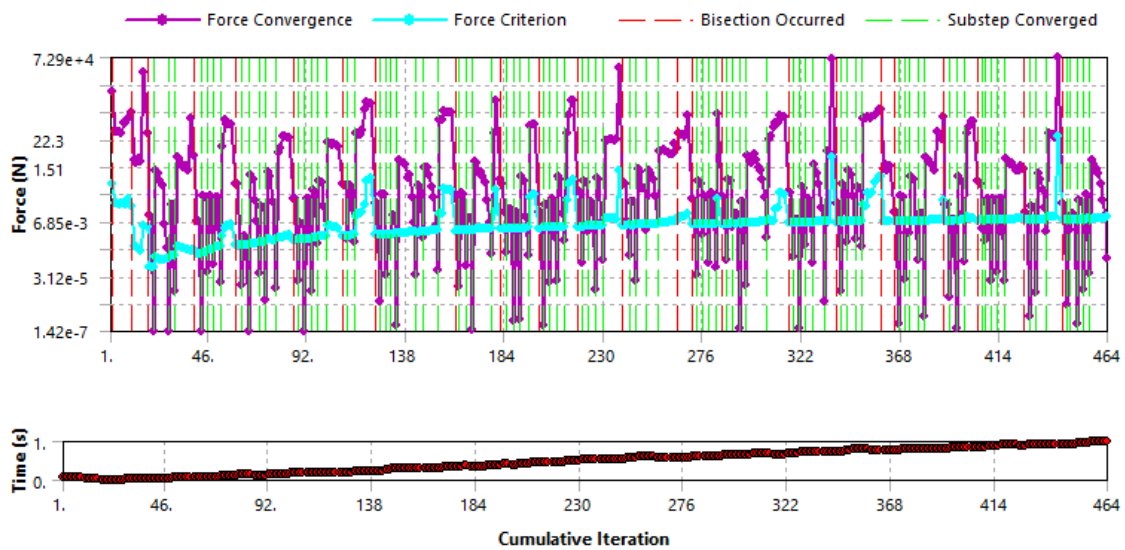

Figure 14 - Force convergence information, Case 2